

Engine 3TNV70  
Engine power 11,2 kW - 15,3 HP  
Operating Weight 1.540 - 1.650 kg

**ES 15 SR**

**Concrete solutions. Always**



# TECHNICALS SPECIFICATIONS

Operating weight with canopy (with rubber tracks)	kg	1.540
Operating weight with cabin (rubber tracks)	kg	1.650
Travelling speed	km/h	1 <sup>a</sup> : 0 ÷ 2,2 / 2 <sup>a</sup> : 0 ÷ 4,2
Slew speed	rpm	12
<b>ENGINE</b>		
Type	YANMAR 3TNV70	
Power (2.100 rpm)	kW - HP	11,2 - 15,2
Displacement	cc	854
Number of cylinders	n°	3
Cooling	water	
Consumption	lt/h	2,4
Alternator	V (A)	12 (35)
Battery	V (Ah)	12 (65)
<b>HYDRAULIC SYSTEM</b>		
Pump type	variable flow	
Pump displacement	cc	8+8+6,5
Pump capacity	lt/min	17,6+17,6+14,3
Max. circuit calibration pressure	bar	210
Auxiliary system:	Max capacity	lt/min 36
	Max pressure	bar 210
<b>PERFORMANCES</b>		
Max digging depth standard arm (optional arm)	mm	2.060 (2.210)
Max dumping height with canopy standard arm (optional arm)	mm	3.285 (3.365)
Max dumping height with cab standard arm (optional arm)	mm	2.380 (2.460)
Bucket breaking force (standard arm) ISO 6015	daN	1.550
Arm breaking force (standard arm) ISO 6015	daN	1.150
Traction force	daN	1.500
Ground bearing pressure with rubber tracks and canopy (with cabin)	kg/cm <sup>2</sup>	0,28 (0,30)
Max slope	60% - 30°	
<b>DIMENSIONS</b>		
Maximum width	mm	990
Total height	mm	2.357
Rear rotation radius	mm	650
Digging arm length std (optional)	mm	950 (1.100)
Tracks width	mm	230
Rollers number (for each side)	n°	3
<b>FILLINGS</b>		
Fuel tank	lt	18
Hydraulic oil tank	lt	20
Hydraulic circuit capacity	lt	30
Cooling system capacity	lt	4
Engine oil	lt	2,8
<b>CONTROLS</b>		
Boom, dipper stick, bucket and turret swing	2 pilot joysticks	
Track movements (included counter rotation)	2 levers	
Dozer blade	mechanical lever	
Auxiliary circuit (simple or double effect)	left pedal	
Boom swing	right pedal	

# ES 15 SR

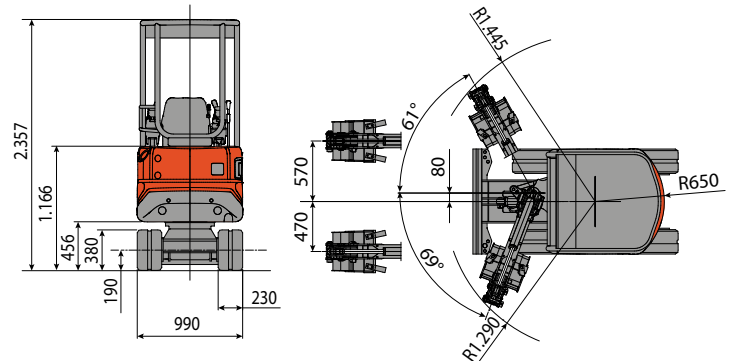
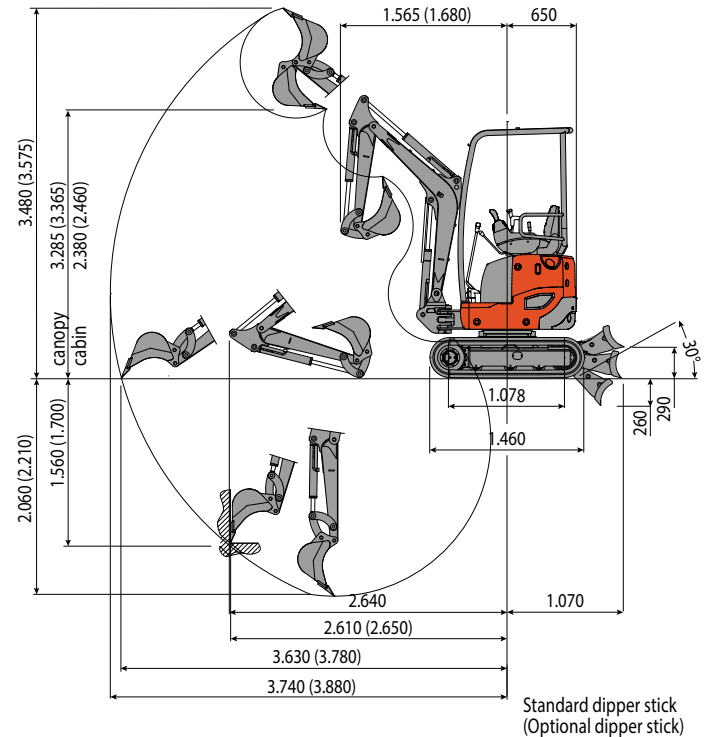

<b>LIFTING CAPACITY</b>					
Opening arm from the rotation's center (m)					
Lifting capacity (kg) at 1.0 m height					
	1,5	2	2,5	3	MAX
Frontal and lowered dozer blade	750	460	380	325	280
Frontal and lifted dozer blade	540	380	265	165	160
Lateral	400	270	160	120	100

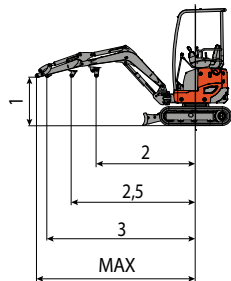

The lifting capacity is based on the ISO 10567 and it does not exceed more than the 75% of static tipping load or more than the 87% of the hydraulic lifting capacity of the machine.



**EUROCOMACH**

Sampierana S.p.A.

47021 S.Piero in Bagno (FC)

via Leonardo da Vinci, 40

Tel +39 0543.904211

Fax +39 0543.918520

www.eurocomach.com